



4" Single Port

Flanged CL 150 – 600
Buttweld



4" Flowgrid® Valve with Series 20 Pilot

SECTIONAL VIEW

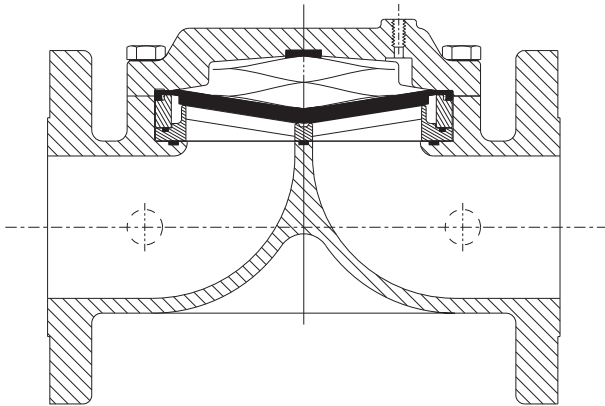

OVERPRESSURE PROTECTION

The Flowgrid® Valve is bi-directional and has a full ANSI rating on both the inlet and outlet. Overpressure protection is required only if the pressure can exceed the flange or body rating.

The pilots, like most regulators, may have an outlet pressure rating lower than the inlet pressure rating. If this is the case then some external form of overpressure protection must be provided for the pilot.

Anytime the Flowgrid® valve or pilot system is exposed to pressure in excess of its rating it should be inspected for damage.

The 4" Flowgrid® Valve is a versatile, economical, and easy to maintain pilot operated valve for both gas and liquid applications. The valve is designed to be used in conjunction with a self contained pilot control system as pictured. The valve combines large capacity and easy in line maintenance with a compact size to make it ideal for skid mounted, vault, and enclosure installations.

SPECIFICATIONS

Size	4"
Body Style	Single Port (4")
End Connections	4" CL150, 300, 600 Flanged & Buttweld
Temperature	Working -20°F to 150°F Emergency -40°F to 175°F
Max. Operating Differential	800 psi
Max. Emergency Differential	1000 psi
Min. Differential	Refer to graph on page 2
Cracking Differential	Refer to graph on page 2
Max. Inlet Pressure	1480 psig*
Outlet Pressure Range	Limited By Pilot
Flow Direction	Bi-Directional**
Body Taps	Two 1/4" - 18NPT

* Limited by pilot or flange rating

** Reverse flow by changing pilot connections and reversing spring case

MATERIALS OF CONSTRUCTION

Body & Spring Case	ASTM A 216 GR WCB Carbon Steel
Throttle Plate	17 - 4PH Stainless Steel
Diaphragm	Nitrile/Nylon*
O-Ring & Seals	Nitrile, Optional (Viton)
Bolting	ASTM A 193 GR B-7 or Equal
Spring	301 Stainless Steel

*Refer to diaphragm selection chart on page 2

STOCK NUMBERS

4" Single Port Valve	Stock #	Weight
150# Flange	FG-39	103 lbs.
300# Flange	FG-40	117 lbs.
600# Flange	FG-41	145 lbs.
150-300# Buttweld	FG-63	86 lbs.
600# Buttweld	FG-64	98 lbs.

DIMENSIONS

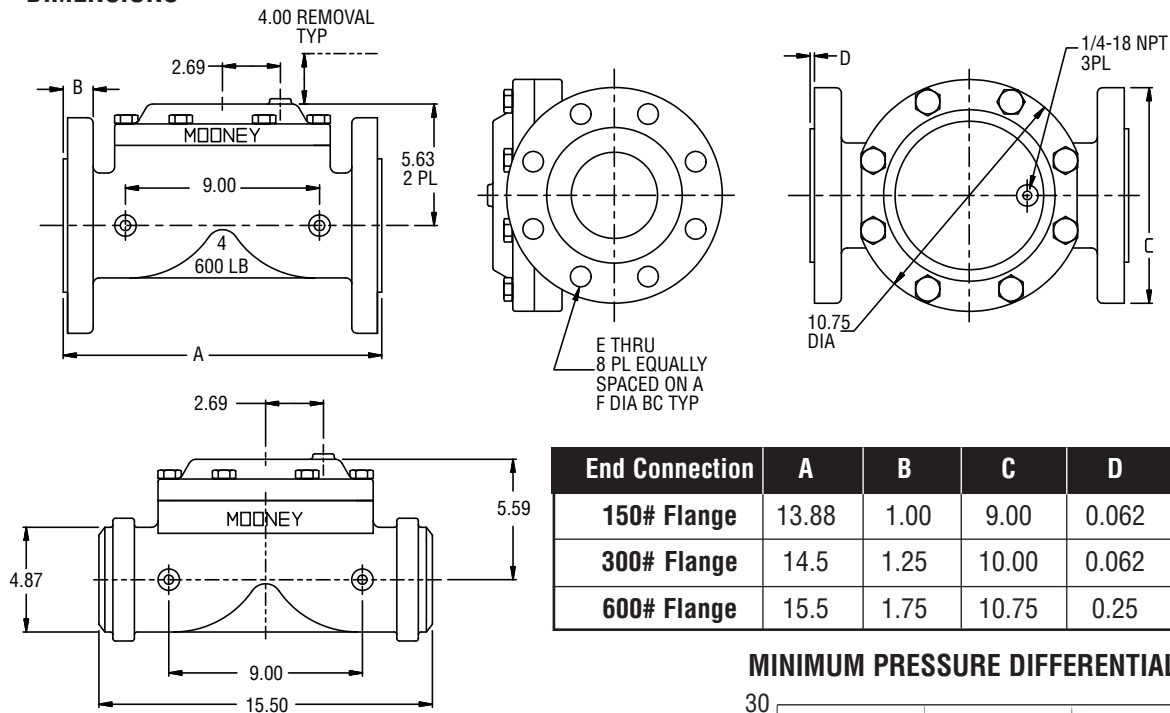

End Connection	A	B	C	D	E	F
150# Flange	13.88	1.00	9.00	0.062	0.750	7.50
300# Flange	14.5	1.25	10.00	0.062	0.875	7.87
600# Flange	15.5	1.75	10.75	0.25	1.00	8.50

FLOW COEFFICIENTS AND CONSTANTS

4" Single Port Valve				Swage Factor	
Percent Capacity	Cv	C1	Cg	1.5:1	2:1
100%	172	38	6500	0.97	0.95
75%	142	37	5300	0.98	0.96
50%	100	35	3550	0.99	0.98
35%	76	35	2700	1.00	1.00

NOTE: Allow a 5% factor of safety when calculating relief capacity

MINIMUM PRESSURE DIFFERENTIAL VS. CAPACITY

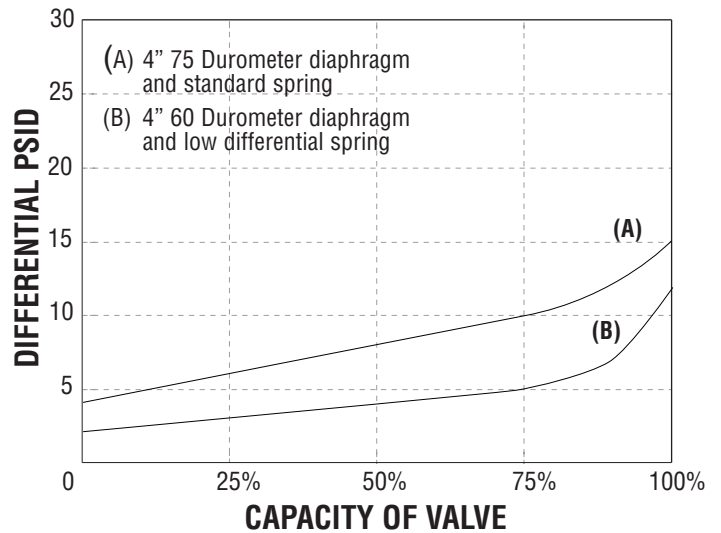

DIAPHRAGM SELECTION

Compound	Temp. Range (Degrees F)	Maximum Differential	Characteristics	Recommended Applications
75 Duro	-20 to 150	1000 psid	Best All Around Material	60 psid to Max. Differential
60 Duro	-25 to 150	300 psid	Best Shutoff at Low Differential Pressure	Low Differential (100 psid or less) or Low Temperature
80 Duro High ACN	-5 to 175	1000 psid	Higher Abrasion and Swelling Resistance	High Differential (400 psid or higher) or Abrasive Conditions with Distillates
80 Duro Low ACN	-20 to 150	1000 psid	Higher Abrasion Resistance and Low Temperature Flexibility	High Differential (400 psid or higher) or Abrasive Conditions at Low Temperatures